

NOTE 1 THIS PRODUCT IS DELIVERED SEPARATELY.  
 ▲ 2 AS SHOWN IN THE FIGURE, THIS PRODUCT SHALL BE USED ASSEMBLED TO A CONNECTOR UNIT 'DH3\*B-27S'.  
 A CLAMP 'DH-27-CMB(7.3)' IS NEEDED WHEN ASSEMBLING THE UNIT.  
 3 A RECOMMENDED SCREW TIGHTENING FOR COVERS TO BE FROM 0.1 TO 0.15 N · m.

2	PC	UL94V-0 BLACK	5	STEEL	TRIVALENT BLACK CHROMATE		
1			4	STAINLESS STEEL			
			3	STAINLESS STEEL	PLATING : NICKEL 0.1μm MIN.		
NO.	MATERIAL	FINISH . REMARKS	NO.	MATERIAL	FINISH . REMARKS		
UNITS		SCALE	COUNT	DESCRIPTION OF REVISIONS	DESIGNED	CHECKED	DATE
mm		2 : 1	2	DIS-E-002831	TU. TANIGUCHI	KN. ICHIKAWA	09. 06. 25
<b>HRS</b> HIROSE ELECTRIC CO., LTD.		APPROVED : A0. SUZUKI	09. 05. 07	DRAWING NO. EDC3-126627-00			
		CHECKED : KN. ICHIKAWA	09. 05. 07	PART NO. DH-27-CT1B			
		DESIGNED : MO. SHIMOYAMA	09. 05. 07	CODE NO. CL244-0030-2-00			
		DRAWN : MO. SHIMOYAMA	09. 05. 07			1/2	

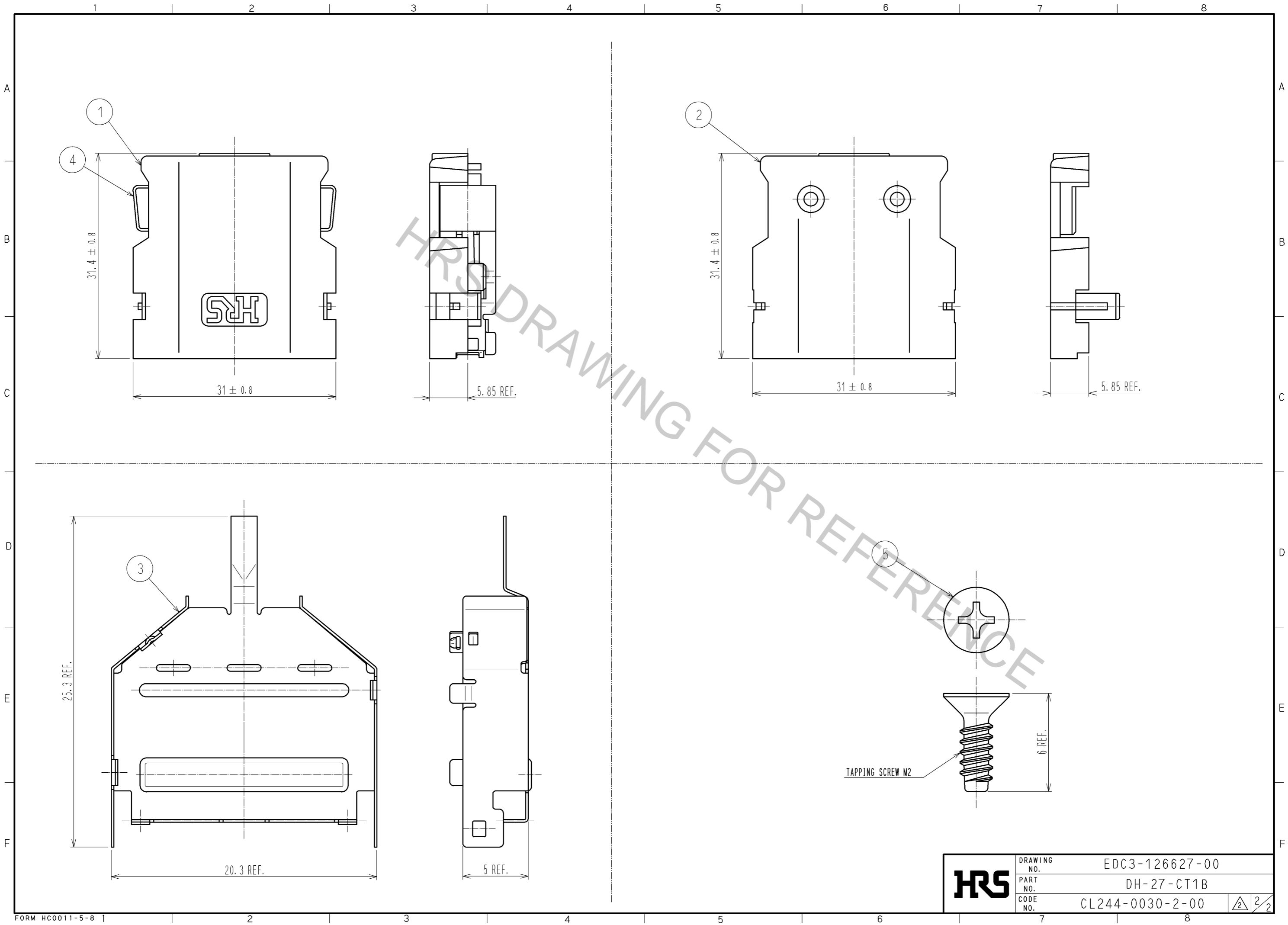

<b>HRS</b>	DRAWING NO.	EDC3-126627-00	
	PART NO.	DH-27-CT1B	
	CODE NO.	CL244-0030-2-00	