

Apr.1.2017 Copyright 2017 HIROSE ELECTRIC CO., LTD. All Rights Reserved.

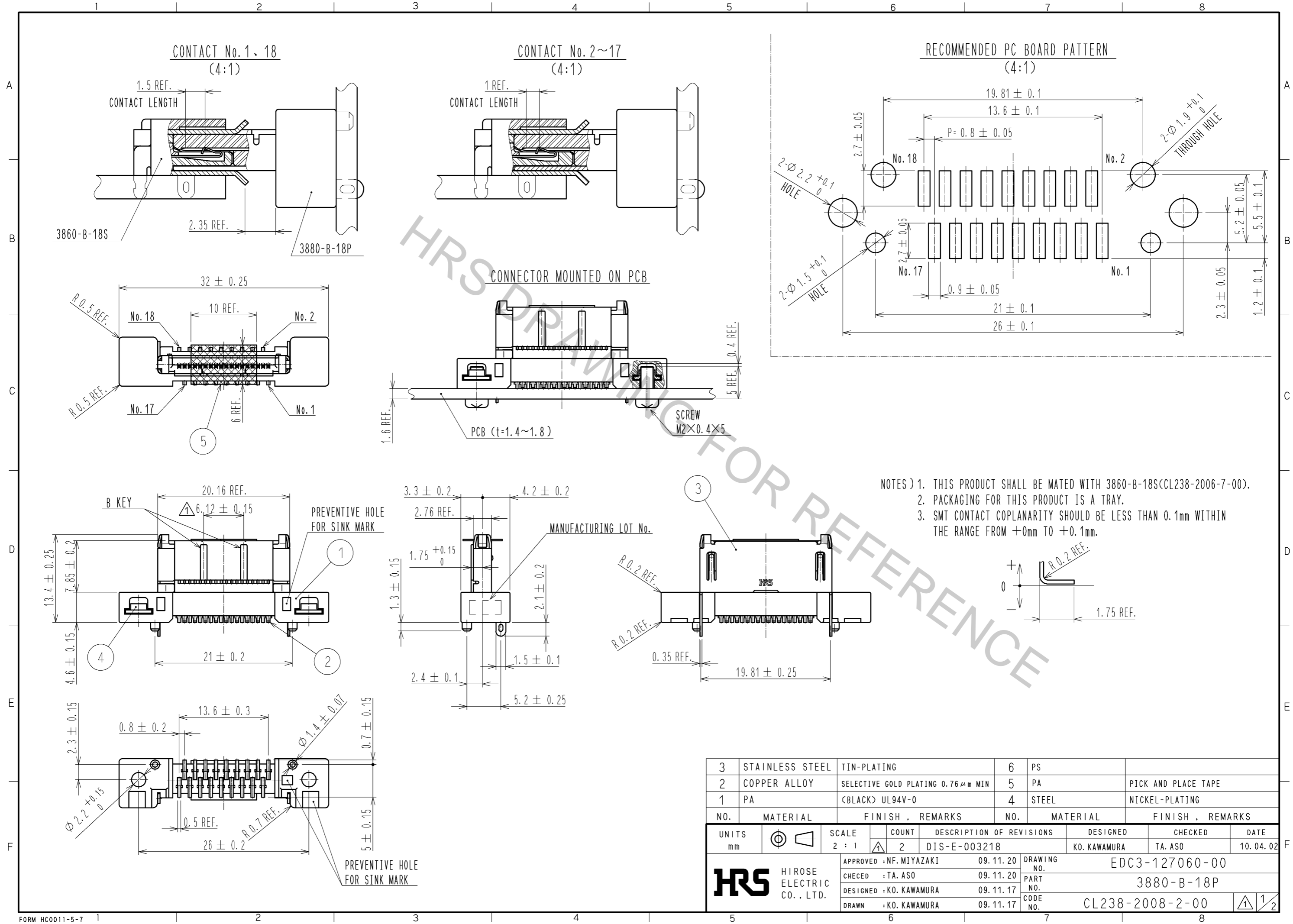

- NOTES) 1. THIS PRODUCT SHALL BE MATED WITH 3860-B-18S(CL238-2006-7-00).
 2. PACKAGING FOR THIS PRODUCT IS A TRAY.
 3. SMT CONTACT COPLANARITY SHOULD BE LESS THAN 0.1mm WITHIN THE RANGE FROM +0mm TO +0.1mm.

3	STAINLESS STEEL	TIN-PLATING	6	PS			
2	COPPER ALLOY	SELECTIVE GOLD PLATING 0.76μm MIN	5	PA	PICK AND PLACE TAPE		
1	PA	(BLACK) UL94V-0	4	STEEL	NICKEL-PLATING		
NO.	MATERIAL	FINISH . REMARKS	NO.	MATERIAL	FINISH . REMARKS		
UNITS mm		SCALE 2 : 1	COUNT 2	DESCRIPTION OF REVISIONS DIS-E-003218	DESIGNED KO. KAWAMURA	CHECKED TA. ASO	DATE 10.04.02
HRS HIROSE ELECTRIC CO., LTD.		APPROVED : NF. MIYAZAKI 09.11.20	DRAWING NO. EDC3-127060-00				
		CHECED : TA. ASO 09.11.20	PART NO. 3880-B-18P				
		DESIGNED : KO. KAWAMURA 09.11.17	CODE NO. CL238-2008-2-00				
		DRAWN : KO. KAWAMURA 09.11.17			1/2		

1. PUT CONNECTORS (40 PCS MAX) INTO THE DEDICATED TRAY.

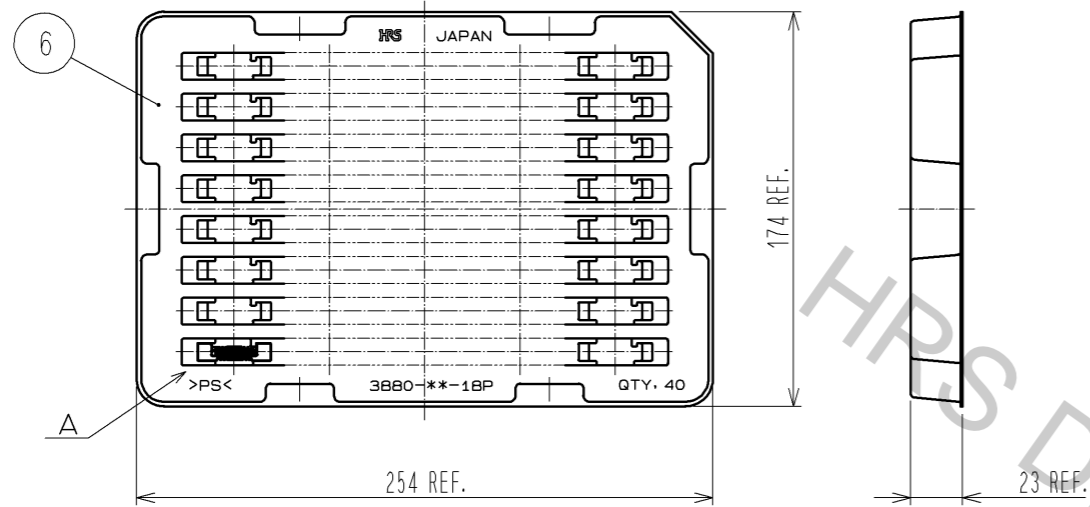

2. PILE FIVE TRAYS CONTAINING CONNECTORS, AND THEN PUT ONE TRAY WITHOUT CONNECTORS ON TOP AS A LID.

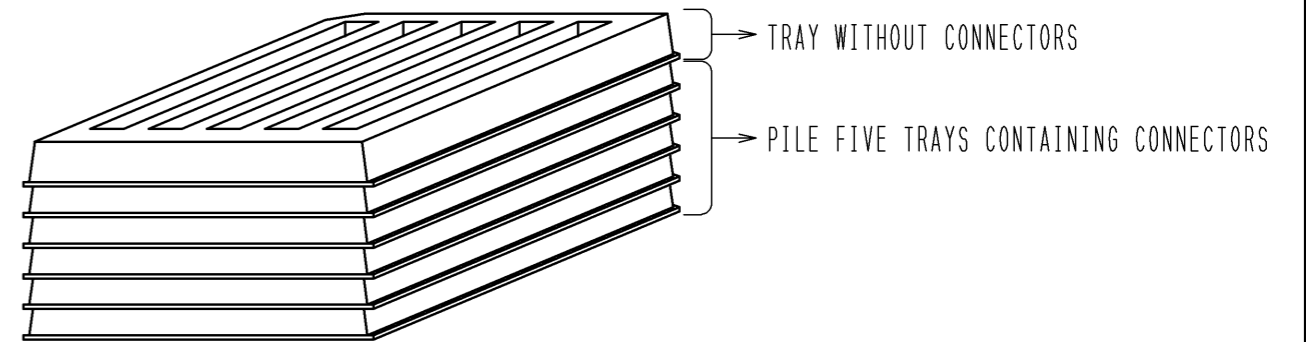

3. SANDWICH THE TRAYS BETWEEN THE CARDBOARD. BUNDLE THEM WITH PP BAND OR THE SIMILAR. THEN PUT BUNDLES INTO THE CARTON BOX IN TWO ROWS.

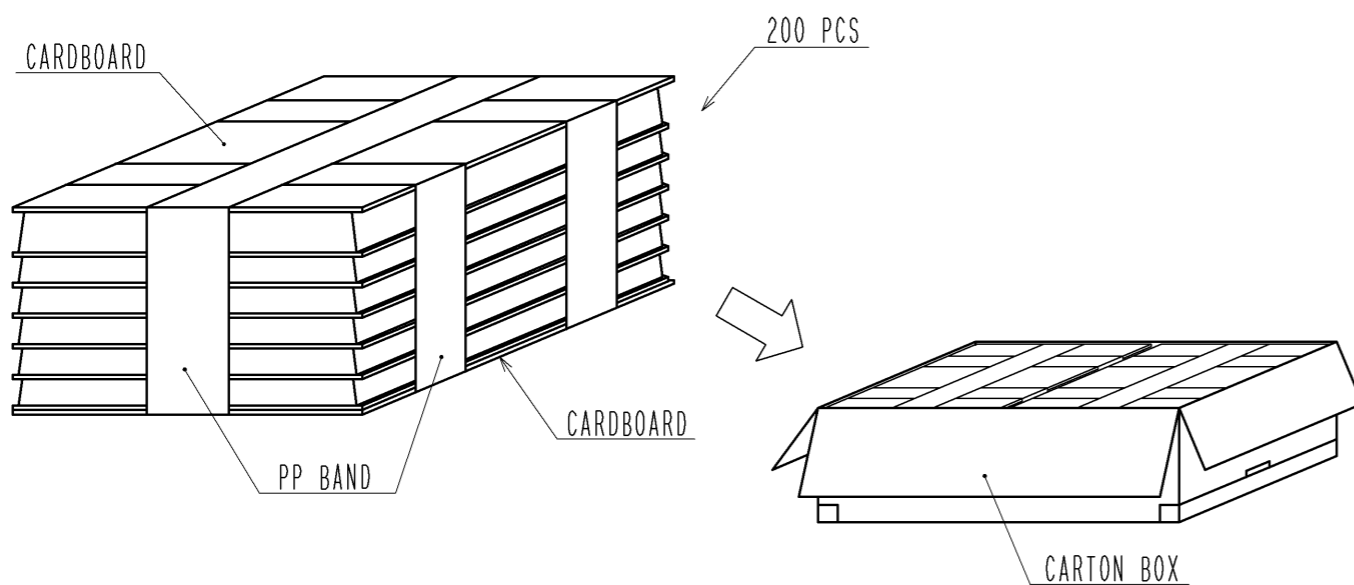

4. CLOSE THE CARTON BOX AND SEAL WITH A TAPE

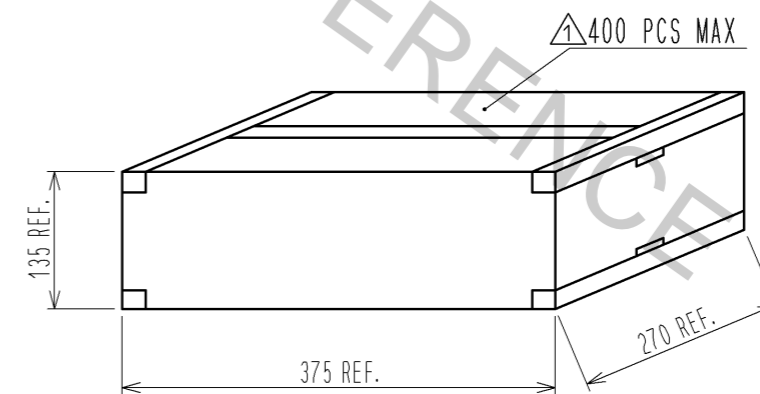

HRS	DRAWING NO.	EDC3-127060-00	 2/2
	PART NO.	3880-B-18P	
	CODE NO.	CL238-2008-2-00	