

† These items must be replaced by TE Connectivity to ensure reliability of the tool. See Section 6.

Figure 1

## 1. INTRODUCTION

This instruction sheet covers the use and maintenance of STRATO-THERM Die Head Assembly 314915-1. The head assembly is used in Pneumatic Crimping Tool 69015 to crimp size 12-10 AWG STRATO-THERM Terminals and Splices with insulation barrel feature.

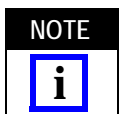

All dimensions on this sheet are in millimeters [followed by inches in brackets].

Read these instructions completely and understand them before using the head assembly.

Reasons for reissue of this document are provided in Section 7, REVISION SUMMARY.

## 2. DESCRIPTION (Figure 1)

The head assembly components include a nest and indenter for crimping the product wire barrel, and an insulation anvil and insulation indenter for crimping the product insulation barrel. There is an adjustment pin for the insulation crimp that can be placed in any of three positions. Position 1 is for the smallest insulation sizes and position 3 is for the largest.

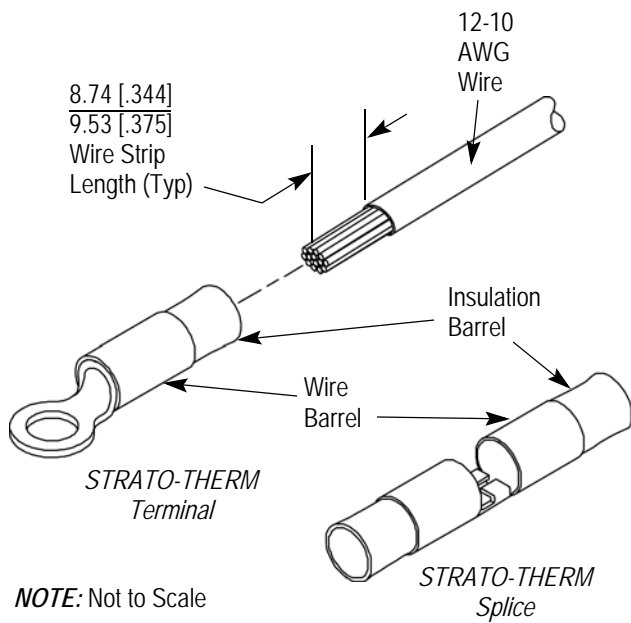

NOTE: Not to Scale

Figure 2

A wire stop prevents the insulation from entering the product wire barrel, and also acts as a guard to prevent injury to fingers. A stop bracket attached to the stop provides support beneath the product during crimping. Figure 2 shows typical product and required wire strip length.

The head assembly can be operated by either tool listed in Section 1, INTRODUCTION. Although there are differences in tools, basic operation and maintenance are similar and are covered in 408-1310. Be sure to read these (or other) related instructions, paying special attention to precautions and air pressure specifications.

### 3. INSTALLING THE HEAD ASSEMBLY (Figure 3)



**AVOID PERSONAL INJURY!** Disconnect the pneumatic tool from its air supply before installing the head assembly.

1. Remove assembly pins from mounting lugs.
2. Using your finger, rotate the top end of the toggle arm toward the front of the tool as far as it will go.
3. Insert toggle lever of head assembly into toggle arm of tool until it snaps into place. (Links of head assembly will go to the inside of the tool mounting lugs.)
4. Insert assembly pins; make sure pins go the whole way through the entire tool and snap into place.

To disassemble: remove pins, lower head assembly away from mounting lugs, rotate head assembly 90°, and remove from toggle arm.

### 4. CRIMPING TERMINALS AND SPLICES



**AVOID PERSONAL INJURY!** Keep fingers clear of crimp area. Be careful to keep body parts and other objects away from trigger until ready to cycle tool.

1. Pre-strip wires to the dimensions in Figure 2.
2. Place terminal or splice in crimping area of die head assembly as shown in Figure 4.
3. Insert stripped wire into terminal or splice so that the wire butts against the wire stop. (If properly stripped, wire insulation will not enter the product wire barrel.)

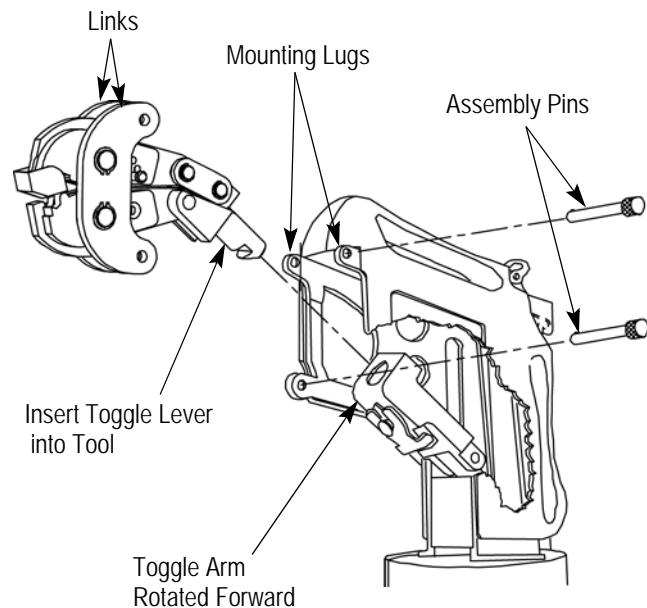

Assemble Head with Tool Power Disconnected

Figure 3

4. Cycle head assembly. Press tool trigger and hold it down until crimping stroke is complete, then release trigger.
5. Remove crimped product; for splices, repeat steps 2 through 4 for the other end.
6. Inspect crimps for items shown in Figure 5 and pull lightly on wire to be sure insulation crimp will hold. Reject all nonconforming crimps.

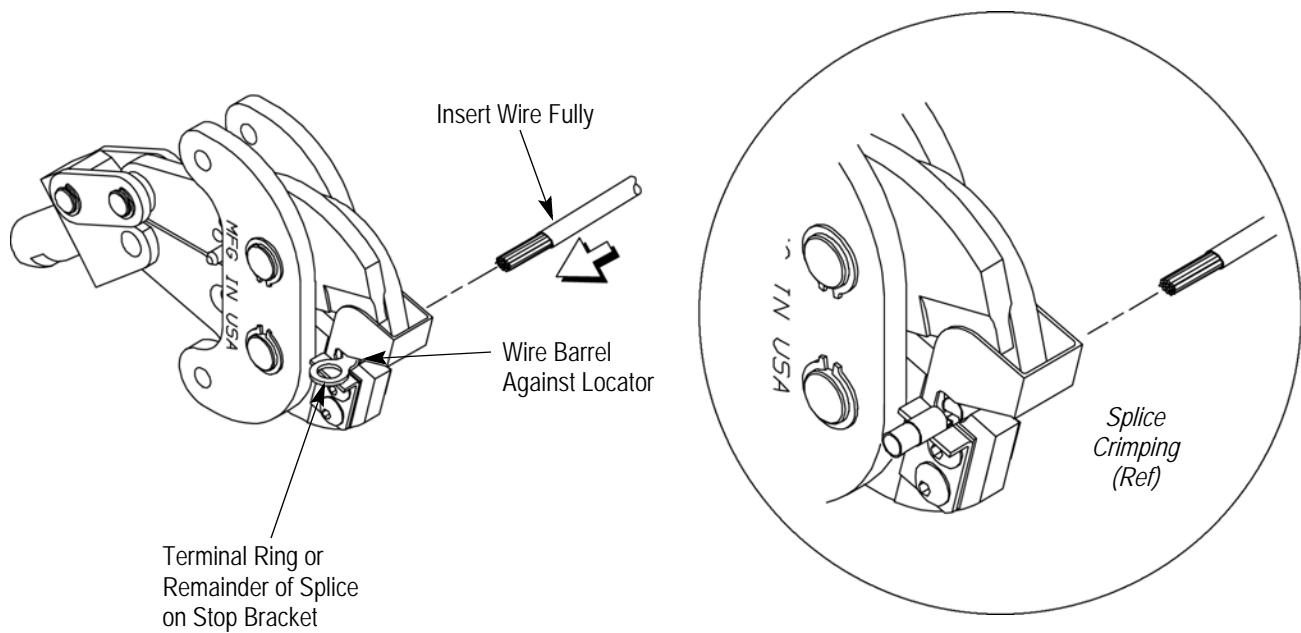

Figure 4

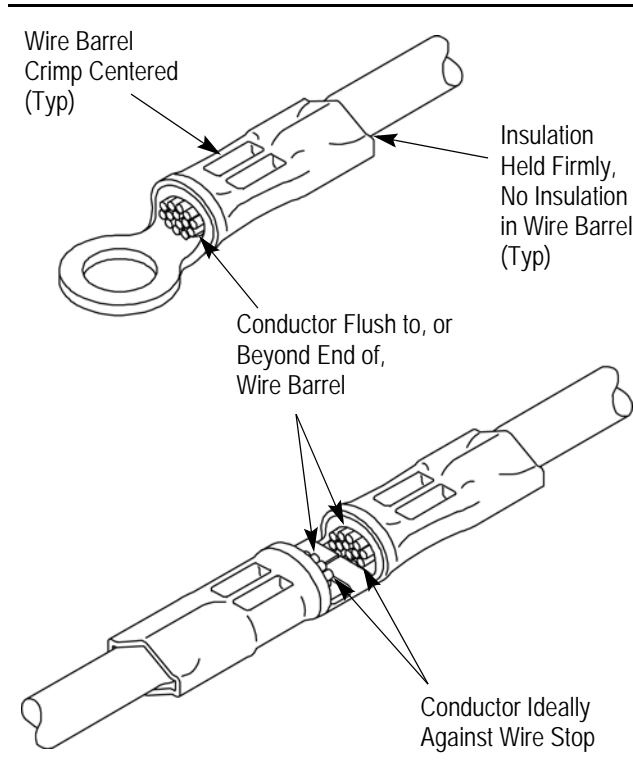

Figure 5

## 5. MAINTAINING THE HEAD ASSEMBLY

Inspect the head assembly when you receive it and at regular intervals. When not in use, store it in a clean, dry area.

### 5.1. Daily Maintenance

At the close of each shift, the responsible operator should clean foreign particles from the tool using a soft, clean, lint-free cloth or brush. Make sure all pins and rings are in place, and that the crimp components are undamaged. Lightly lubricate all pins, pivot points, and bearing surfaces using a good grade SAE 20 motor oil. Do not lubricate excessively.



**CAUTION** DO NOT lubricate the surfaces of the crimp components that contact the product. These areas must be kept clean to prevent product slippage during crimping.

### 5.2. Periodic Inspection

We recommend that the following inspections be conducted at least once a month by quality control personnel. More frequent inspections should be conducted if your work environment, company standards, or amount of tool use indicates the need.

#### A. Visual Inspection

With the head assembly removed from the tool, remove all lubrication and accumulated film by immersing the head in a mild commercial degreaser. Then:

1. Check for missing or defective pins or retaining rings. Replace parts as necessary. See Section 6, REPLACEMENT AND REPAIR.
2. Closely inspect dies for damage, giving special attention to bearing surfaces and surfaces that contact the product.

*Suggested Plug Gage Design  
(Wire Barrel Crimp Area)*

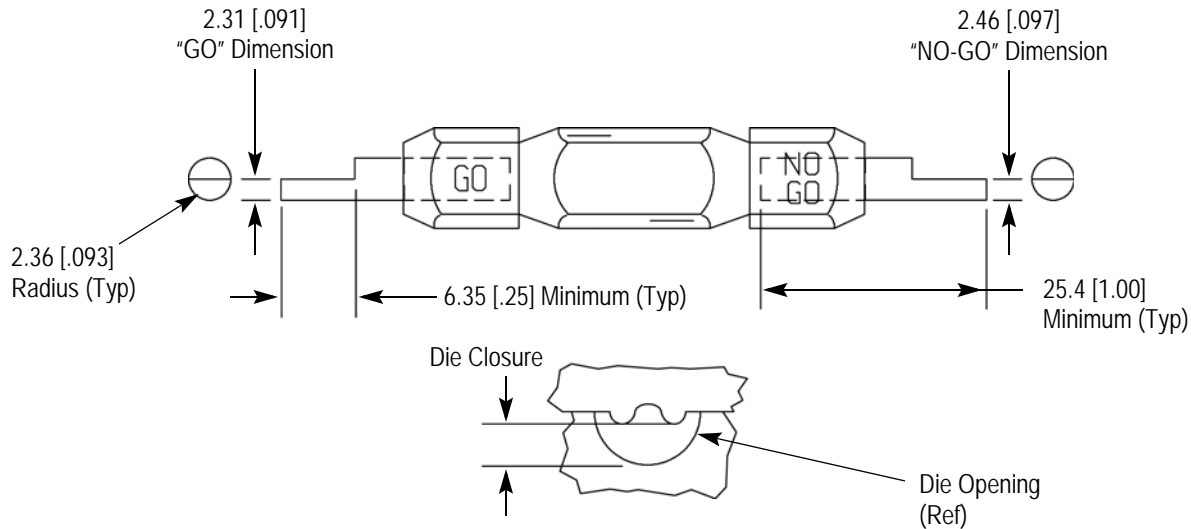

Figure 6

Worn, cracked, pitted, or chipped die surfaces, or other obvious wear or damage to the head assembly requires removal from service. Return the entire assembly for evaluation and repair. See Section 6, REPLACEMENT AND REPAIR.

#### B. Gaging the Die Closure (Figure 6)

The die head assembly is inspected and tested for correct closure dimensions before being shipped. However, we recommend periodic die closure measurement to ensure uniform performance over the life of the head assembly.

Figure 6 shows dimensions for manufacture of a plug gage for inspecting the closure of the wire barrel dies. If the wire barrel dies close properly, and the adjustment pin is set properly for the size wire insulation you are using, the insulation barrel dies should also close properly. So, there is no need for a plug gage to measure the insulation barrel die closure.

Perform the inspection as follows:

1. Remove head assembly from tool as described in the disassembly paragraph in Section 3, INSTALLING THE HEAD ASSEMBLY. Then wipe oil, film, and debris from the crimping area and plug gage.
2. Hold the dies in the closed position, but DO NOT apply pressure beyond initial contact.
3. Align the plug gage GO element with the die opening. Push the element straight into the opening, but without forcing it. The GO element must pass completely through the opening.

4. Align the NO-GO element and try to insert it straight into the die opening. The NO-GO element may begin entry, but must not pass through the opening.

If die closure gaging shows that dies conform to dimensions, lubricate them with a thin coat of any good SAE 20 motor oil. If not, replace the dies.

For additional information regarding the use of plug gages, see instruction sheet 408-7424.

#### 6. REPLACEMENT AND REPAIR

Customer-replaceable parts are shown in Figure 1. A complete inventory should be stocked and controlled to prevent lost time when replacement of parts is necessary. Order replacement parts through your field representative, or call 1-800-526-5142, or send a facsimile of your purchase order to 717-986-7605 or write to:

CUSTOMER SERVICE (038-035)  
TYCO ELECTRONICS CORPORATION  
PO BOX 3608  
HARRISBURG PA 17105-3608

For customer repair service, call 1-800-526-5136.

#### 7. REVISION SUMMARY

Since the previous version of this document, the following changes were made:

- Removed references to obsolete tool 314937-1.
- Updated document to corporate requirements.