

**VICOR CONFIDENTIAL**

THIS DOCUMENT AND THE DATA DISCLOSED HEREIN OR HEREWITH IS NOT TO BE REPRODUCED, USED, OR DISCLOSED IN WHOLE OR IN PART TO ANYONE WITHOUT PERMISSION OF VICOR CORP.

REV.	DESCRIPTION	DATE	APPROVED
1	Revised per E080380	JS 02/28/08	REJH

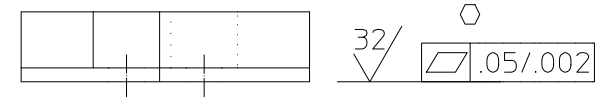
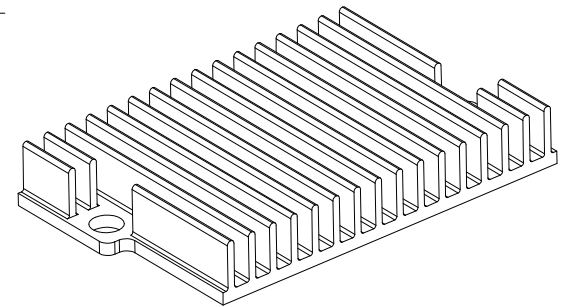
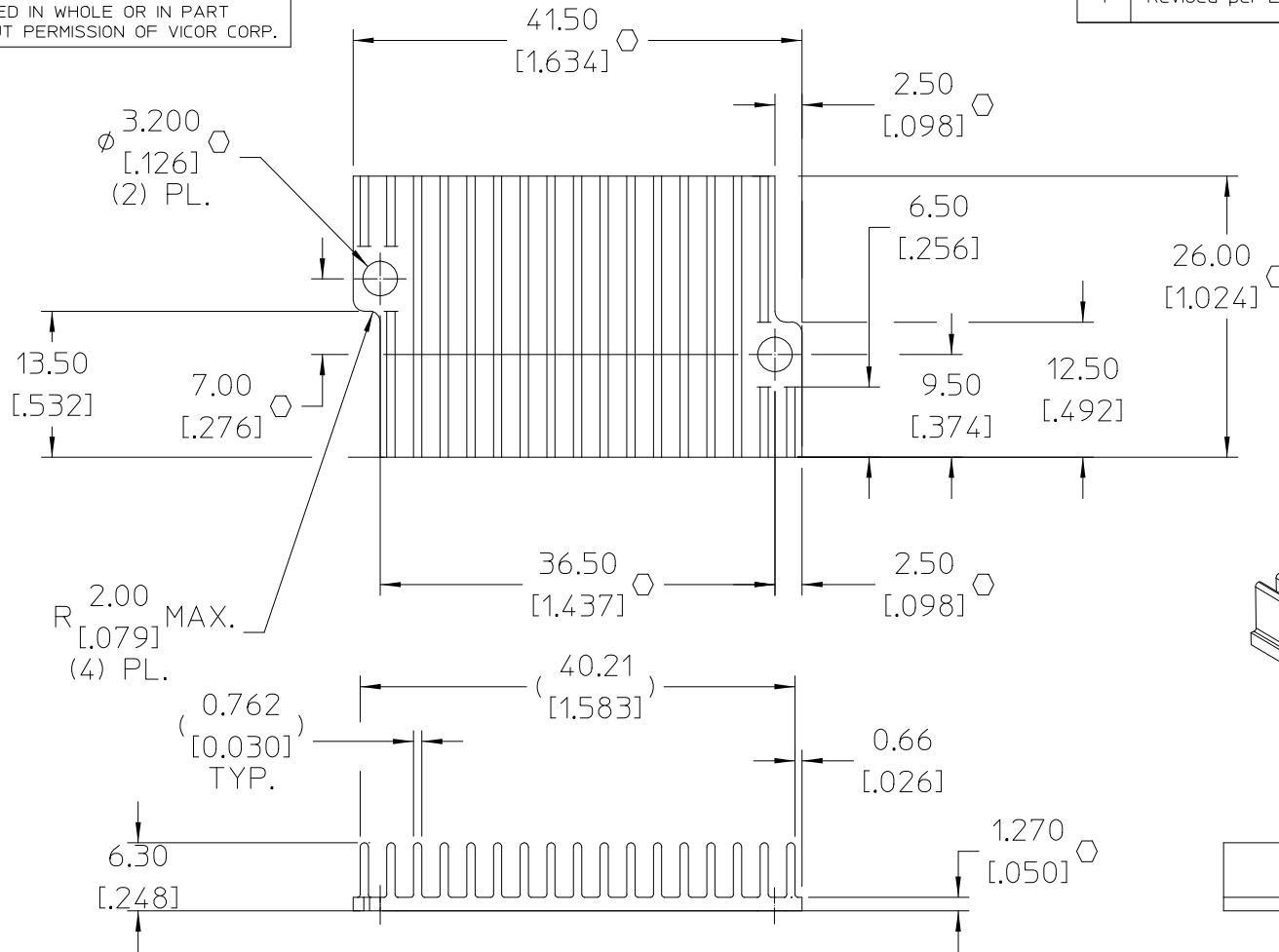

**NOTES:**

1. MAKE FROM VICOR PART NO. 32620.
2. FINISH: ELECTROLESS NICKEL PLATE PER ASTM B607-91, THICKNESS .000120" TO .000300" (3 TO 8μM).
3. REMOVE ALL BURRS AND SHARP EDGES.
4. "O" DENOTES CRITICAL CHARACTERISTIC FOR LOT INSPECTION.
5. RoHS COMPLIANT, LEAD FREE PER CST-0001 LATEST REVISION.

DRAWN BY <i>R.E.J.Hickey</i>		DATE 08/09/07			
UNLESS OTHERWISE SPECIFIED DIMENSIONS ARE MM [INCH] TOLERANCES ARE: DECIMALS ANGLES .XX= ±0.25 [.01] ±1° .XXX= ±0.127 [.005]					
THIRD ANGLE PROJECTION 		SIZE <b>B</b>	FSCM NO. <b>67131</b>	DWG NO. <b>34069</b>	REV <b>1</b>
DO NOT SCALE DRAWING		SCALE 2:1	SHEET 1 OF 1		